

Voltage readings

[DC] GE tubes: idle, w/rt chassis ground

[DC] RCA tubes: idle w/rt chassis ground

AC peak-to-peak signal (measured with scope) using 0.5V 500Hz sine wave input, all controls straight up (12:00) [GE tubes]

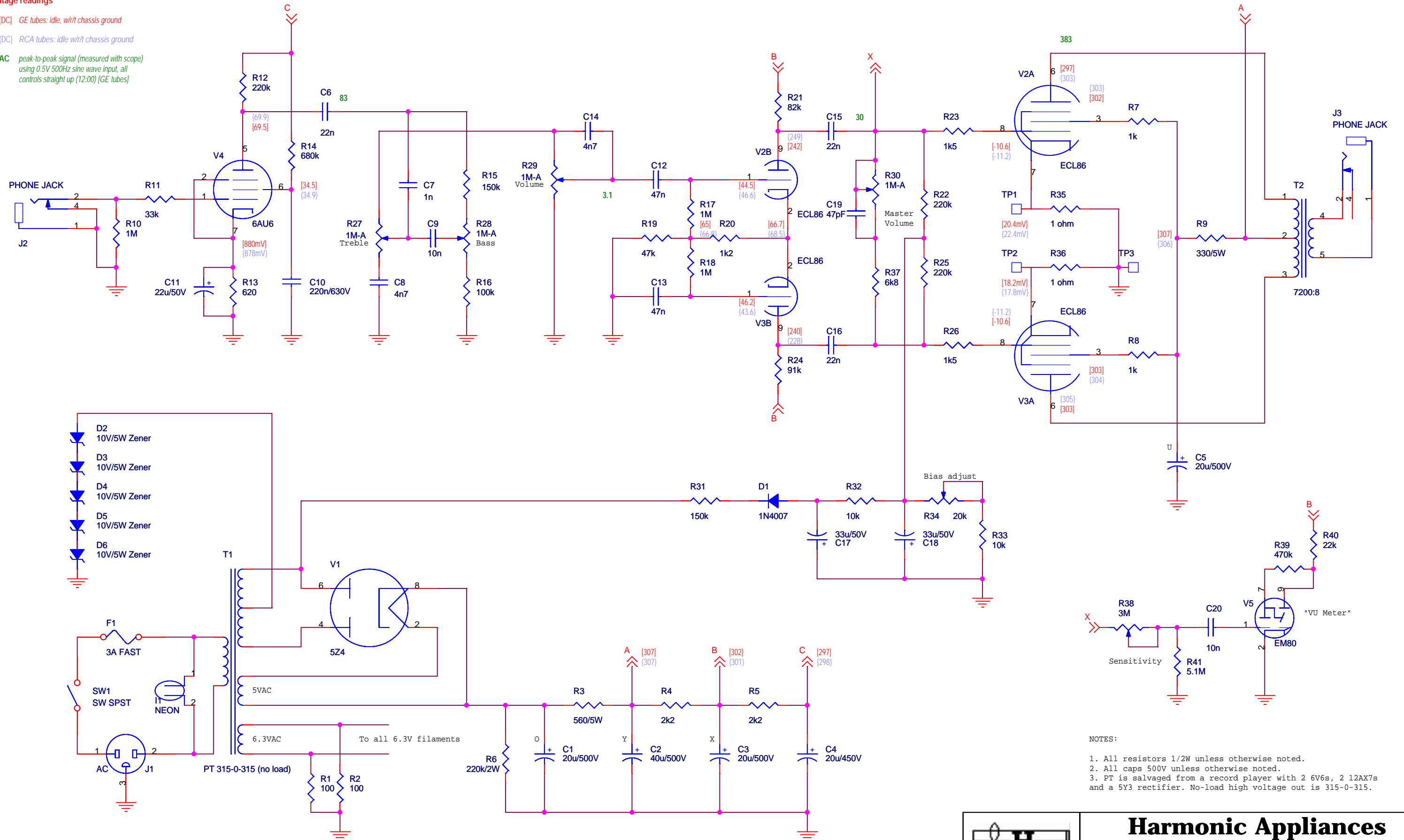

- D2 10V/5W Zener
- D3 10V/5W Zener
- D4 10V/5W Zener
- D5 10V/5W Zener
- D6 10V/5W Zener

- NOTES:
1. All resistors 1/2W unless otherwise noted.
 2. All caps 500V unless otherwise noted.
 3. PT is salvaged from a record player with 2 6V6s, 2 12AX7s and a 5Y3 rectifier. No-load high voltage out is 315-0-315.



Harmonic Appliances

Highway 86

Size: B | Module: based on Aharon Colman's Hwy86
 Date: Sunday, July 11, 2004 | Sheet 1 of 1 | Rev.: B1
 Copyright (c) 2004 Mark Lavelle | All rights reserved.