

Voltage readings

AC peak-to-peak 200Hz sine wave input, all controls at maximum (measured with oscilloscope)

[DC] Idle, with respect to chassis ground

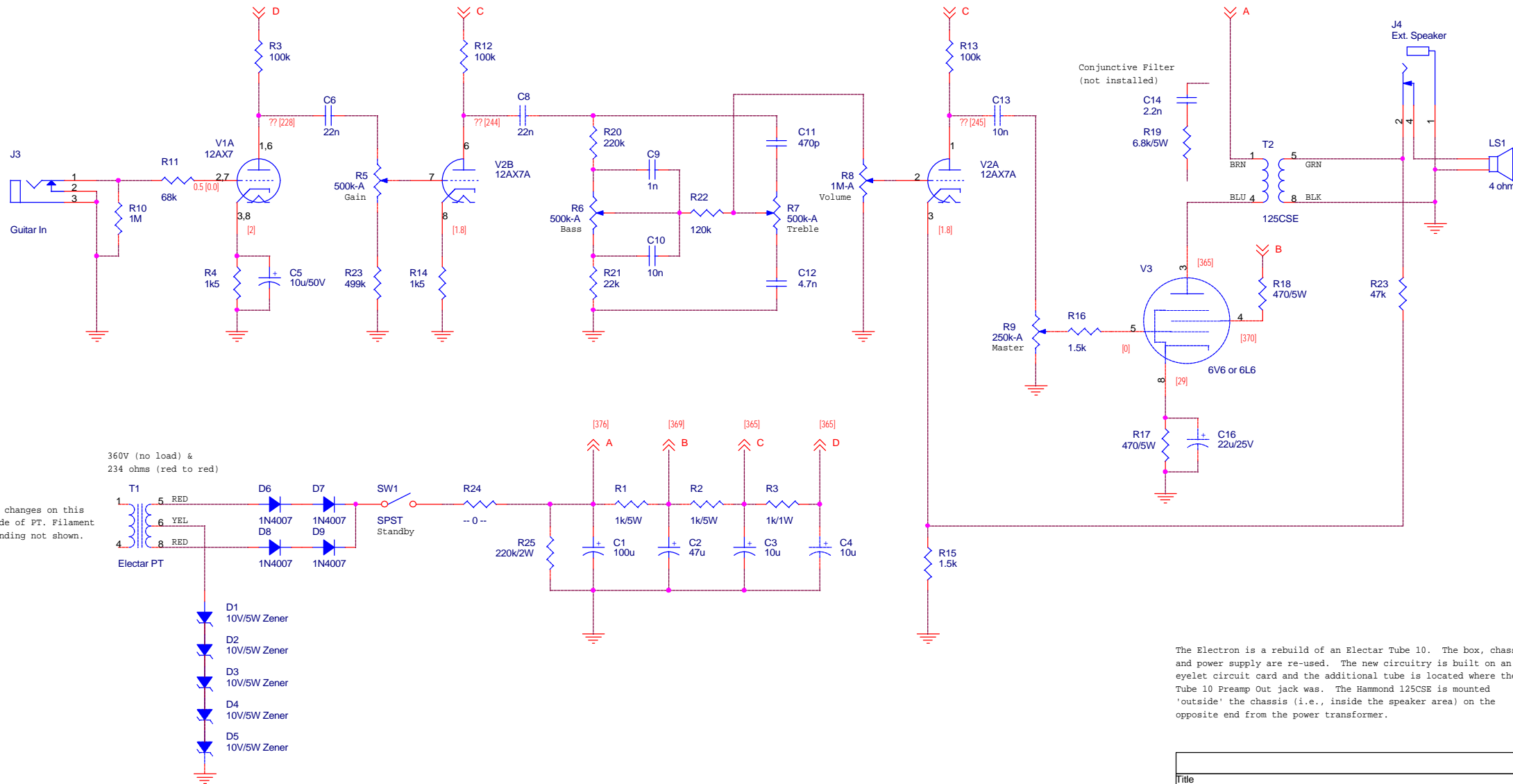

The Electron is a rebuild of an Electar Tube 10. The box, chassis and power supply are re-used. The new circuitry is built on an eyelet circuit card and the additional tube is located where the Tube 10 Preamp Out jack was. The Hammond 125CSE is mounted 'outside' the chassis (i.e., inside the speaker area) on the opposite end from the power transformer.

Title		
Electron Guitar Amp		
Size	Document Number	Rev
B	Rev. 1	1
Date:	Saturday, February 02, 2002	Sheet 1 of 1