

[xxx] = measured DC voltages  
(with respect to chassis ground)

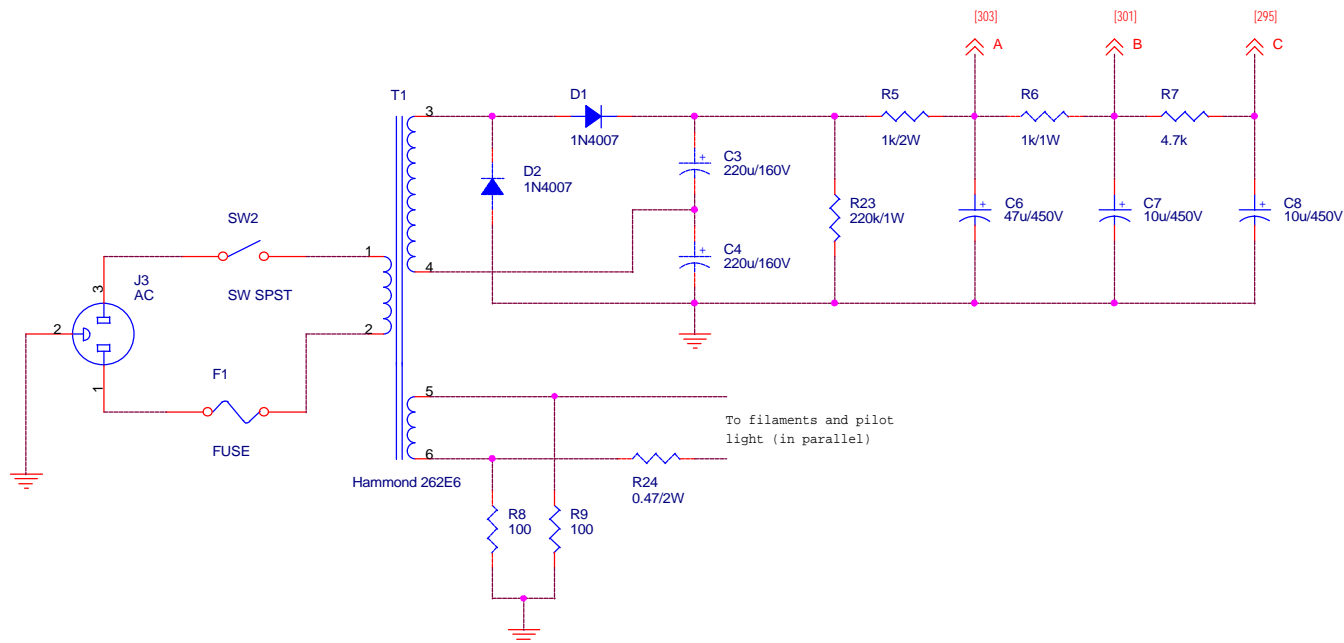
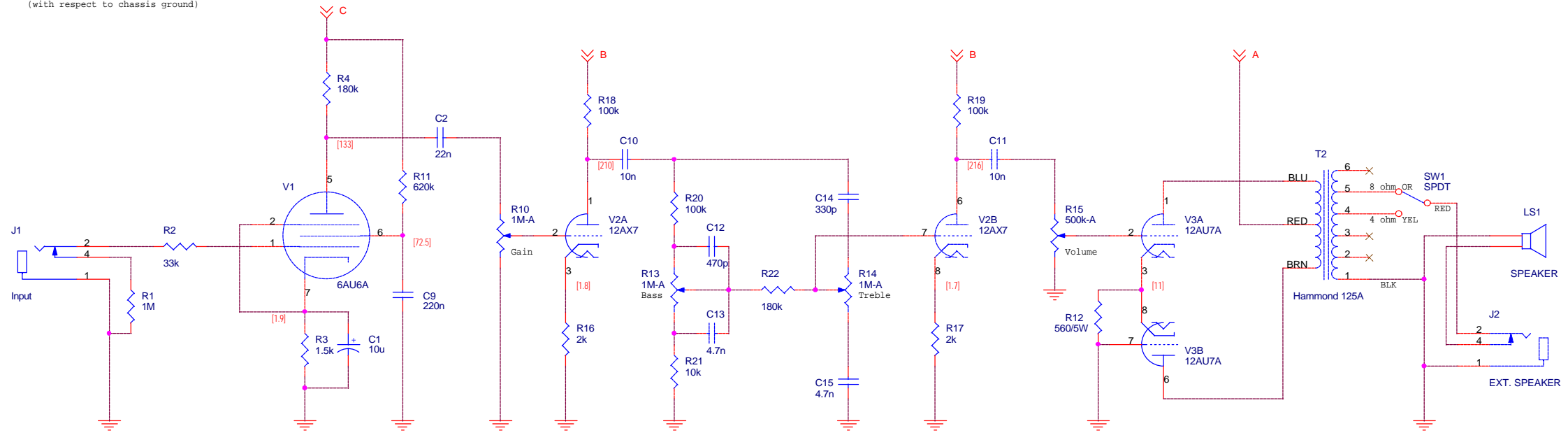

- Notes:
- 1) All resistors are 1/2W unless otherwise specified
  - 2) All capacitors are 400V (minimum) unless otherwise specified
  - 3) A 12BH7A also works well in V3
  - 4) 12AT7 or 12AY7 also work well in V2
  - 5) Speaker LS1 is Radio Shack 40-1242E
  - 6) R24 is optional, but recommended if local power is over 120VAC

Harmonic Appliances		
Title		
<b>The Decimator (a self-split 12AU7 guitar amp)</b>		
Size	Document Number	Rev
B	N/A	2
Date:	Friday, March 08, 2002	Sheet 1 of 1